



OPTIONAL EQUIPMENT

- Centering and Diaphragm holding device

MISC.

- Support adapted to the tubehead
- 4 wheels
- Guidance handle

QUALITY ASSURANCE

- CE Manufacturing process

When operating a stationary or mobile unit, it may be interesting to have an assistance for the tube positioning. Precise positioning at angle and height is indeed easier with the proper support adapted for the handling of such equipment.

UTS01 is the right element to help you with your tube handling problems. The tube is held by a strong steel tubing which gives the ability to move the tube in three different axis.

Strong castor wheels are allowing the whole assembly to be moved on flat surfaces. Height adjustment can be either manual or motorised.

MECHANICAL DRAWING

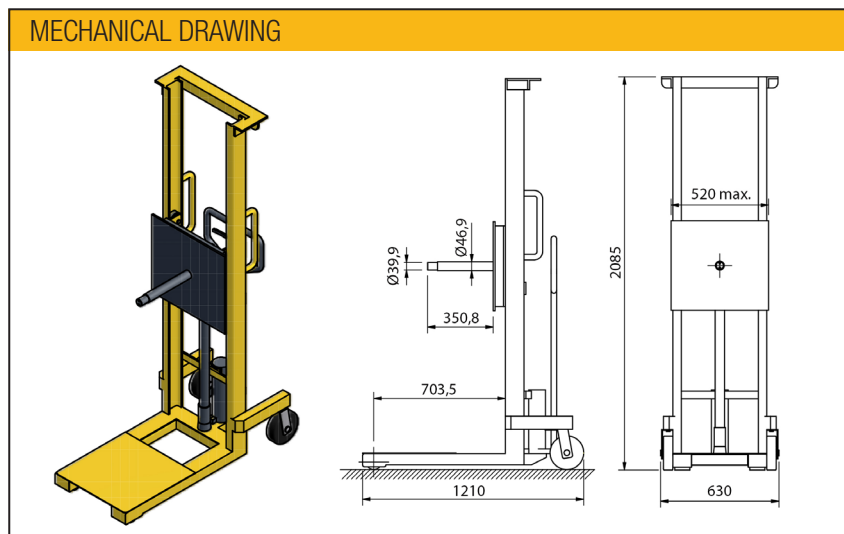

Cost efficient solution

When it is necessary to move the tube closer to an object, simply wheel the structure and you can position the tube where it is desired to perform irradiations.

Tube handling

The tube is handled by a steel handling circle that comes around the tube guides which allows it to move on its own axis.

The tube can be moved up and down (Z axis) either by a motor (UTS02) with up and down switches or by manual operation (UTS01 oil assisted manual pump).

The tube can also be swivelled left or right. The motorised version is acting on an Hydraulic pump with a steel chain to lift the tube on the Z axis.

HV Cables are entering the tube from the top and have sufficient room to follow tube movement.

Steel structure and stability

Due to the heavy weight of a stationary unit, the assembly is made out of welded Steel tubes. The structure is painted and therefore protected against external corrosion. Wheels are swivelling and made to move freely on hard surfaces. Weights are distributed on the surface in such a way that stability on flat surfaces is ensured even with the tube at full height.

The structure also offers an irradiation surface right under the tube for workshop applications like small components radiography that can be placed flat under the tube.

Contact details

Balteau NDT

Rue Voie de Liège, 12
B-4681 Hermalle Sous Argenteau
Belgium

www.balteau.com
balteau@balteau.com
Tel. +32 (0) 4 374 75 75
Fax +32 (0) 4 374 75 85

Distributed by:

